

Scale Model Shed

Explore the **General Carpenter** Trade

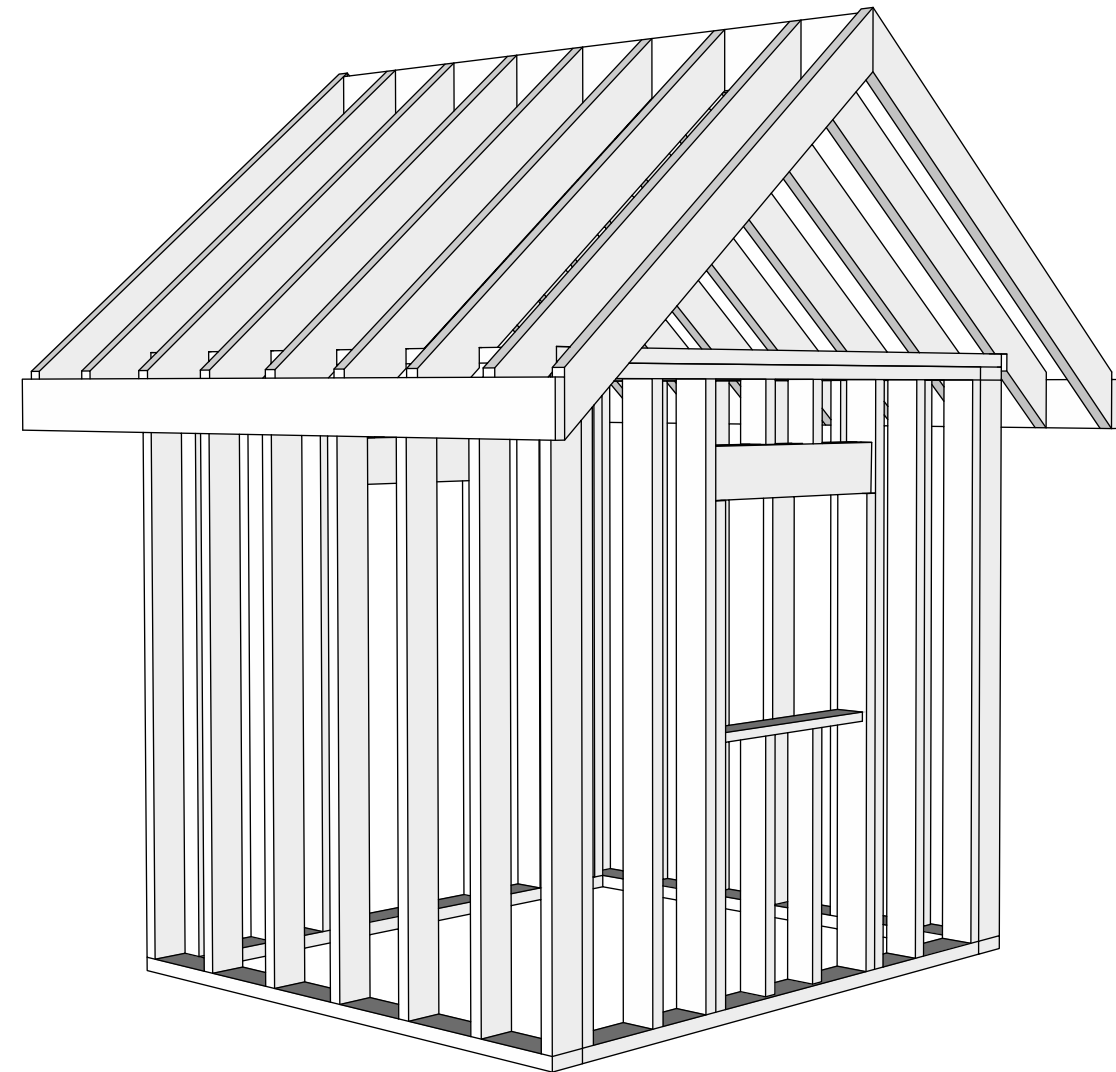

- Do you like...** Working with your hands?
 Building and assembling things?
 Learning by doing?
 Taking things apart?
 Working on things and making them better?

if yes, how about becoming a tradesperson!

Trade Facts

DID YOU KNOW?

While still in high school, you can test out a trade first to see if you like it through a Youth Apprenticeship Program.

OYAP is a high school program that allows you to try a wide variety of apprenticeship careers in the skilled trades such as carpenter, hairdresser, auto mechanic, and more. You start your journey as soon as grade 11 through the Cooperative Education Program.

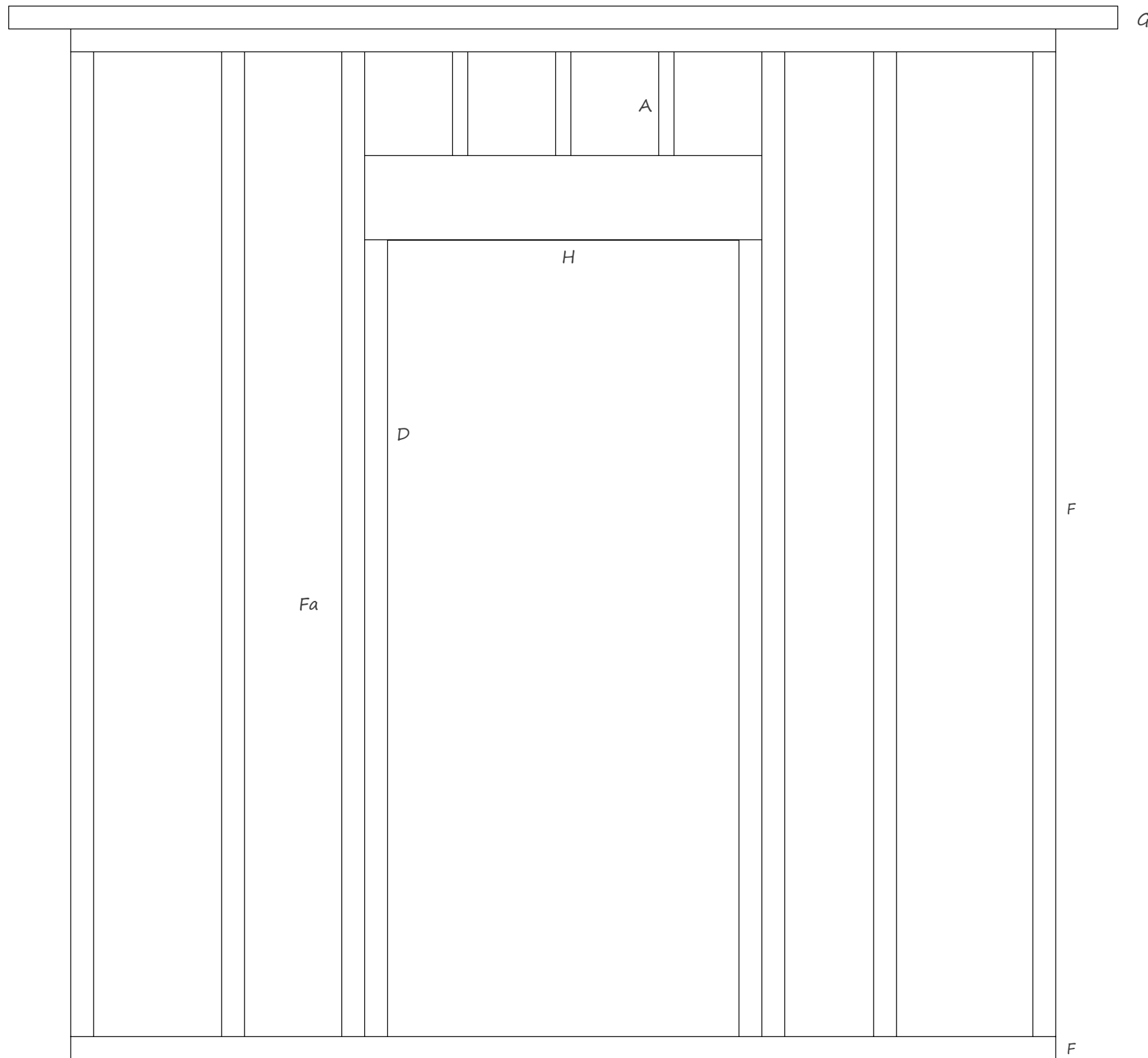

COMPONENTS OF A BEARING DOOR OPENING

A	CRIPPLE
B	
C	
D	TRIMMER
E	
F	STUDS
Fa	KING STUD
G	TOP PLATE
H	HEADER
I	
J	
K	
L	

GENERAL CARPENTER

TRADES DEMAND = JOB OPPORTUNITY

Trade Facts

A **General Carpenter** constructs, renovates and repairs structures made of wood, steel, concrete and other materials in the residential, commercial and industrial construction sectors and in related industries. Specifically.

THE DEMAND FOR SKILLED WORKERS has been increasing steadily for more than a decade

kh design

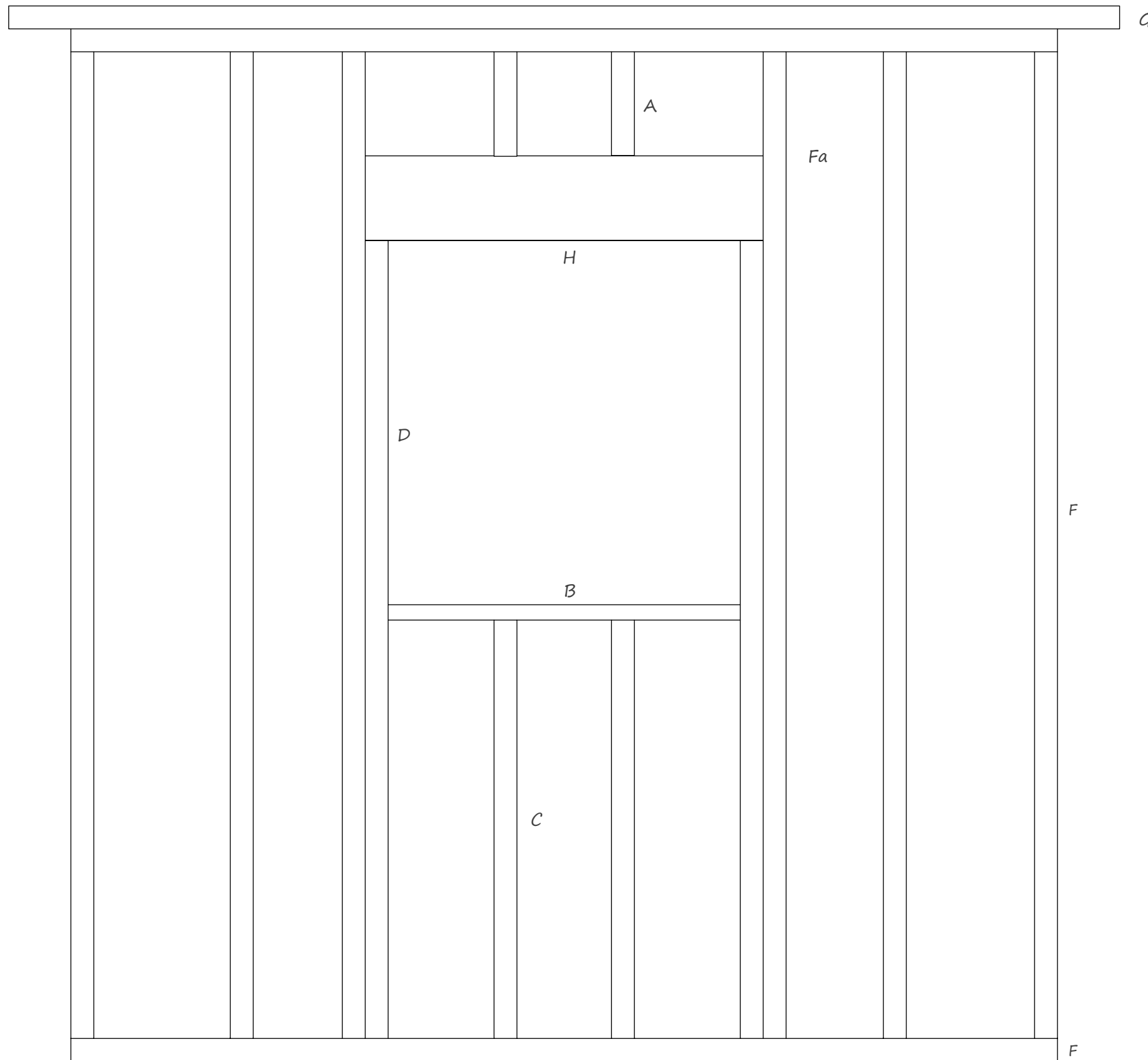

COMPONENTS OF A BEARING WALL OPENING

A	CRIPPLE
B	SILL PLATE
C	CRIPPLE
D	TRIMMER
E	
F	STUDS
Fa	KING STUD
G	TOP PLATE
H	HEADER
I	
J	
K	
L	

GENERAL CARPENTER

LOT OF RETIREMENTS = OPPORTUNITY FOR YOU

Trade Facts

Over the next 10 years, around 250,000 baby boomers will be retiring from the construction industry alone. Employers will be looking to fill these vacated positions with smart, skilled people. You could be one of them.

Skilled trades are considered an "evergreen profession."
That means they will always be needed.

HOW TO GET STARTED

BECOME AN APPRENTICE

CONSTRCT TWO

A	
B	
C	
D	
E	TOP PLATE
F	STUDS
Fa	
G	
H	
I	
J	
K	
L	

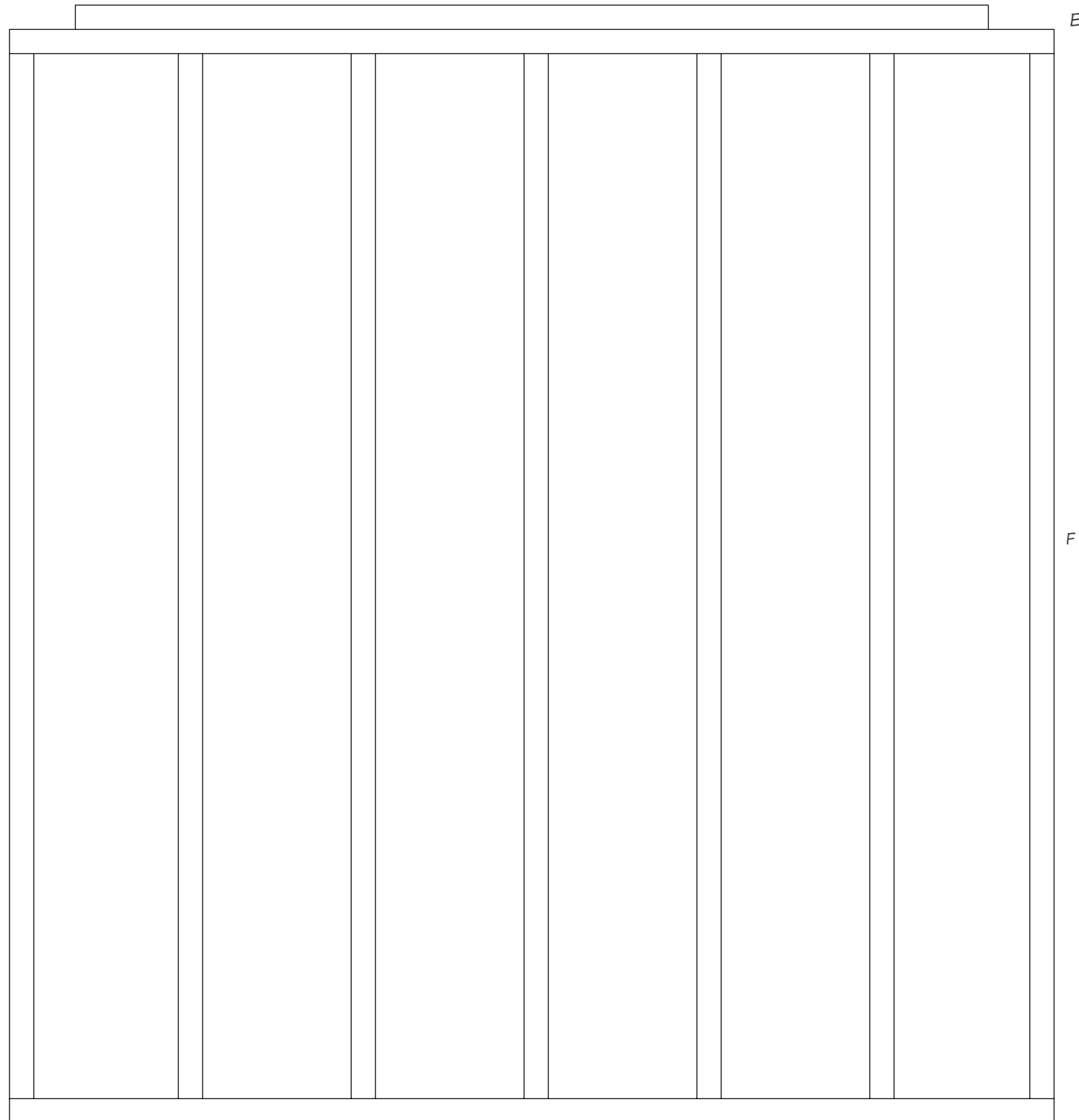

CUTTING LIST

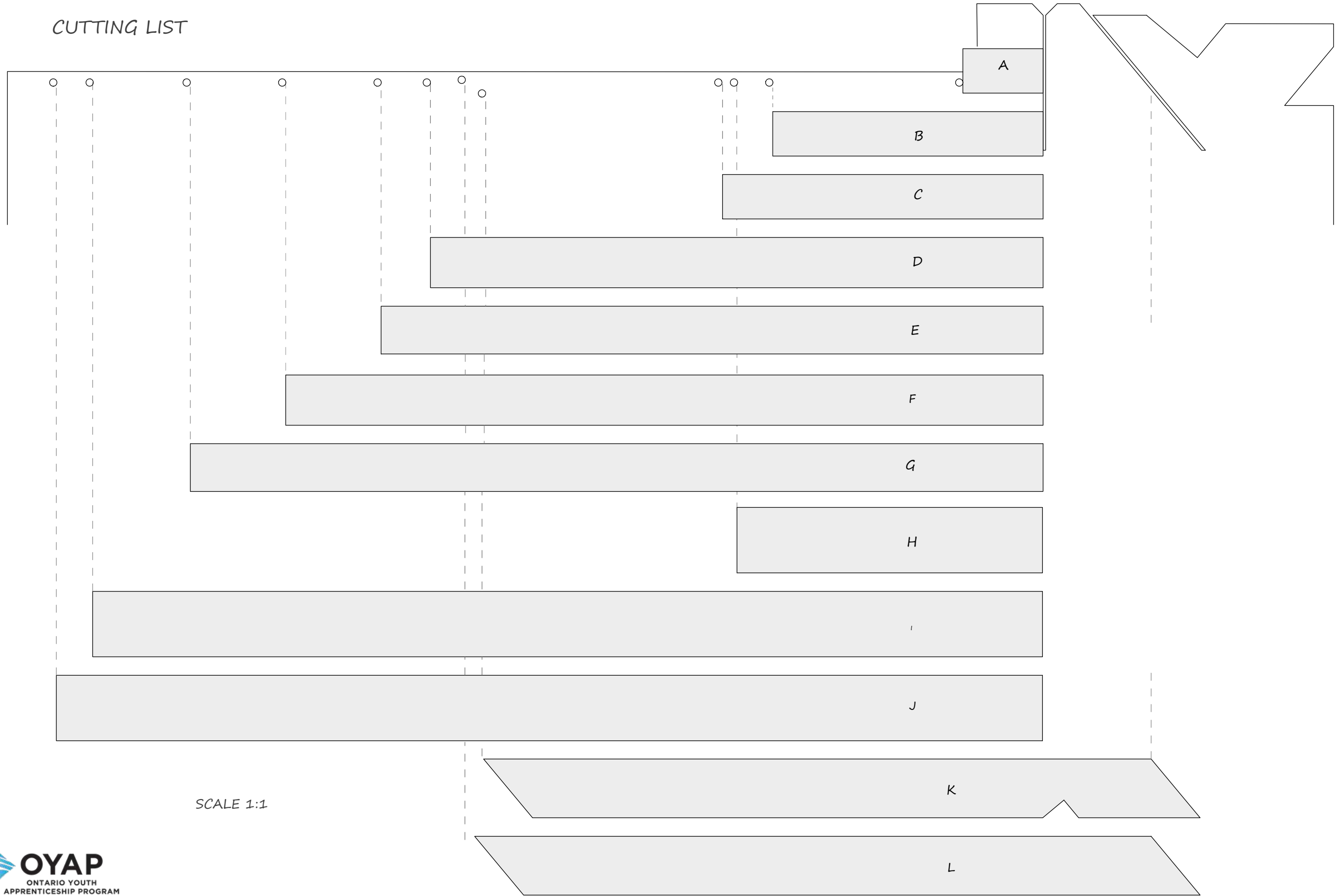

SCALE 1:1

CONSTRUCTION DETAILS

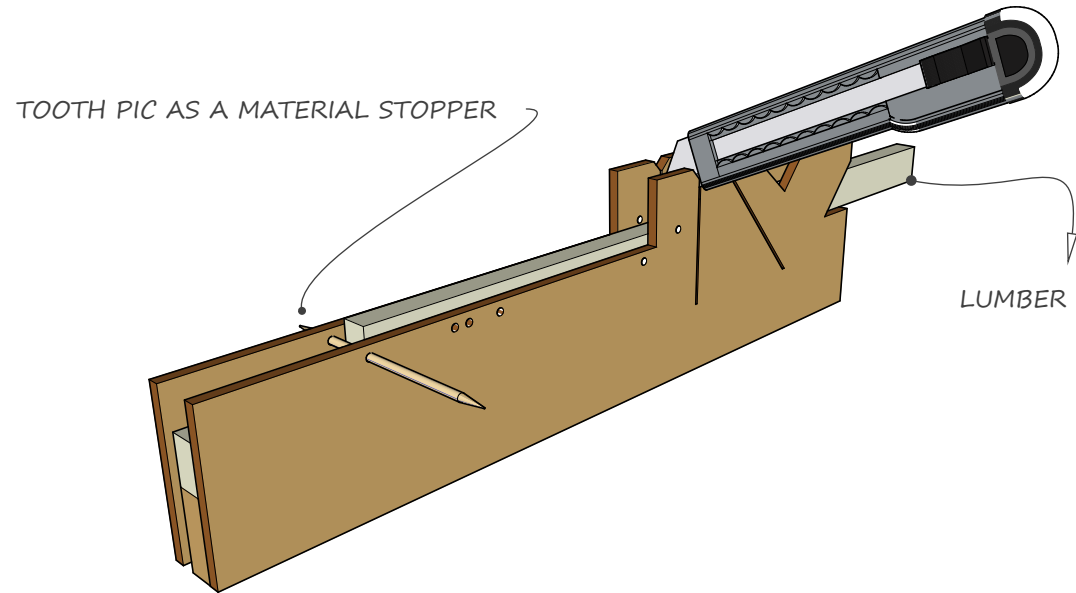

MODEL KNIFE SAFETY

- Never use a knife for any other purposes than cutting (e.g., pry or tighten screws).
- Always use a sharp blade and pick up knives by the handle only.
- Do not grab for a falling knife. When a knife falls jump back out of the way.
- Always carry a knife with the tip pointing downward and with the cutting edge turned away from your body.
- Securely grip the handle of the knife so that it does not slip out of your hands.
- Firmly hold the material that you are cutting.
- Keep your fingers as far away from the blade as possible, but be sure to maintain a safe grasp of the material being cut.
- Avoid using excessive force and trying to make deep cuts. Make several passes when cutting.
- Keep work area clean and organized. Remove the scraps created from cutting.
- When not in use, retract a blade on retractable knives or fit the guard if supplied

CUTTING TRUSSES

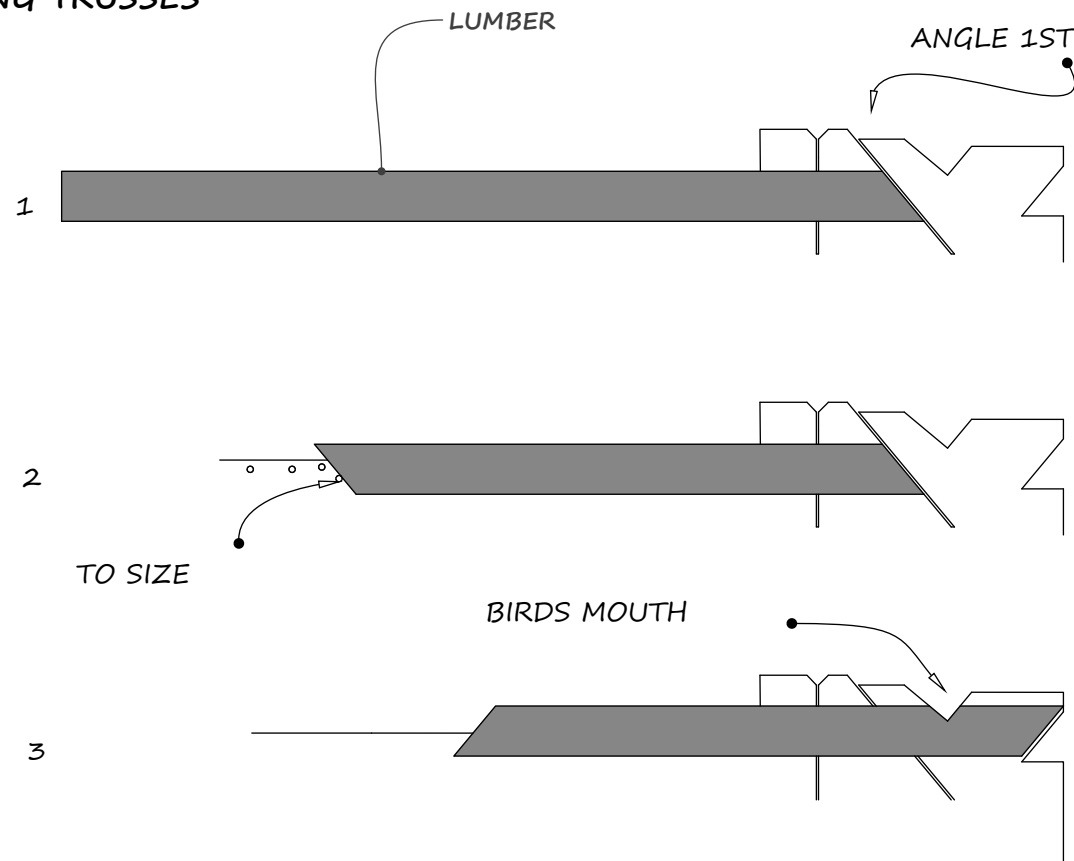

FRAMING TECHNIQUE

